

Diameter Ø58mm Shaft Type/Hollow Type/Built-In Type Incremental Rotary Encoder

■ Features

- Diameter Ø58mm flange type
- Suitable for measuring angle, position, revolution, speed, acceleration and distance
- Power supply: 5VDC, 12-24VDC ±5%

■ Applications

- Various tooling machinery, packing machine and general industrial machinery, etc.

⚠ Please read "Caution for your safety" in operation manual before using.



■ Ordering Information

E58SC **10** - **8000** - **3** - **N** - **24** -

Series	Shaft diameter		Pulse/1Revolution	Output phase	Control output	Power supply	Cable*1
Diameter Ø58mm							
SC: Shaft Clamping	External	10	Refer to resolution	2: A, B 3: A, B, Z 4: A, \bar{A} , B, \bar{B} 6: A, \bar{A} , B, \bar{B} , Z, \bar{Z}	T: Totem pole output N: NPN open collector output V: Voltage output L: Line driver output	5: 5VDC ±5% 24: 12-24VDC ±5%	No mark: Axial/Radial cable type C: Axial/Radial cable connector type CR: Axial connector type CS: Radial connector type
SS: Shaft Synchro		6					
H: Hollow	Inner	12					
HB: Hollow Built-in		Ø12mm					

*1: E58H (hollow shaft) has only radial cable type, radial cable connector type.

■ Specifications

Item	Diameter Ø58mm incremental rotary encoder		
Resolution (P/R)*1	*1, *2, *5, 10, *12, 15, 20, 23, 25, 30, 35, 40, 45, 50, 60, 75, 100, 120, 125, 150, 192, 200, 240, 250, 256, 300, 360, 400, 500, 512, 600, 800, 1000, 1024, 1200, 1500, 1800, 2000, 2048, 2500, 3000, 3600, 5000, 6000, 8000		
Electrical specification	Output phase	A, B, Z phase (line driver output: A, \bar{A} , B, \bar{B} , Z, \bar{Z} phase)	
	Phase difference of output	Output between A and B phase: $\frac{T}{4} \pm \frac{T}{8}$ (T=1 cycle of A phase)	
	Control output	Totem pole output	• [Low] - Load current: Max. 30mA, Residual voltage: Max. 0.4VDC • [High] - Load current: Max. 10mA, Output voltage (power voltage 5VDC): Min. (power voltage-2.0)VDC, Output voltage (power voltage 12-24VDC): Min. (power voltage-3.0)VDC
		NPN open collector output	Load current: Max. 30mA, Residual voltage: Max. 0.4VDC
		Voltage output	Load current: Max. 10mA, Residual voltage: Max. 0.4VDC
		Line driver output	• [Low] - Load current: Max. 20mA, Residual voltage: Max. 0.5VDC • [High] - Load current: Max. -20mA, Output voltage (power voltage 5VDC): Min. (power voltage-2.5)VDC, Output voltage (power voltage 12-24VDC): Min. (power voltage-3.0)VDC
	Response time (rise, fall)	Totem pole output	Max. 1µs (cable length: 2m, I sink = 20mA)
		NPN open collector output	
		Voltage output	
		Line driver output	
Max. Response frequency	300kHz		
Power supply	• 5VDC ±5% (ripple P-P: Max. 5%) • 12-24VDC ±5% (ripple P-P: Max. 5%)		
Current consumption	Max. 80mA (disconnection of the load), Line driver output: Max. 50mA (disconnection of the load)		
Insulation resistance	Over 100MΩ (at 500VDC megger between all terminals and case)		
Dielectric strength	750VAC 50/60Hz for 1 minute (between all terminals and case)		
Connection	Cable type, Axial cable connector type, Axial/Radial connector type		
Mechanical specification	Starting torque	• SC/SS type: Max. 40gf·cm (0.004N·m) • H/HB type: Max. 90gf·cm (0.009N·m)	
	Moment of inertia	• SC/SS type: Max. 15g·cm ² (1.5×10 ⁻⁶ kg·m ²) • H/HB type: Max. 20g·cm ² (2×10 ⁻⁶ kg·m ²)	
	Shaft loading	• SC/SS type-Radial: Max. 10kgf, Thrust: Max. 2.5kgf • H/HB type-Radial: Max. 2kgf, Thrust: Max. 1kgf	
	Max. allowable revolution*2	5,000rpm	
Vibration	1.5mm amplitude at frequency of 10 to 55Hz (for 1 min) in each X, Y, Z direction for 2 hours		
Shock	Approx. Max. 75G		
Environment	Ambient temperature	-10 to 70°C, Storage: -25 to 85°C	
	Ambient humidity	35 to 85%RH, Storage: 35 to 90%RH	
Protection structure	IP50 (IEC standard)		
Cable	Ø5mm, 5-wire (line driver output: 8-wire), 2m, Shield cable (AWG24, core diameter: 0.08mm, number of cores: 40, insulator out diameter: Ø1mm)		
Accessory	Coupling (SC type: Ø10mm, SS type: Ø6mm), Fixing bracket		
Approval	CE (except for line driver output)		
Unit weight	Cable type, Cable connector type	• SC type: Approx. 310g, SS type: Approx. 285g, H type: Approx. 270g, HB type: Approx. 270g	
	Connector type	• SC type: Approx. 230g, SS type: Approx. 205g, HB type: Approx. 200g	

*1: ** pulse is only for A, B phase. (line driver output is for A, \bar{A} , B, \bar{B}) *2: Make sure that Max. response revolution should be lower than or equal to max. allowable revolution when selecting the resolution.
Not indicated resolutions are customizable.

※Environment resistance is rated at no freezing or condensation.

$$[\text{Max. response revolution (rpm)}] = \frac{\text{Max. response frequency}}{\text{Resolution}} \times 60 \text{ sec}$$

Incremental Ø58mm Shaft/Hollow Shaft/Built-In Type

Control Output Diagram

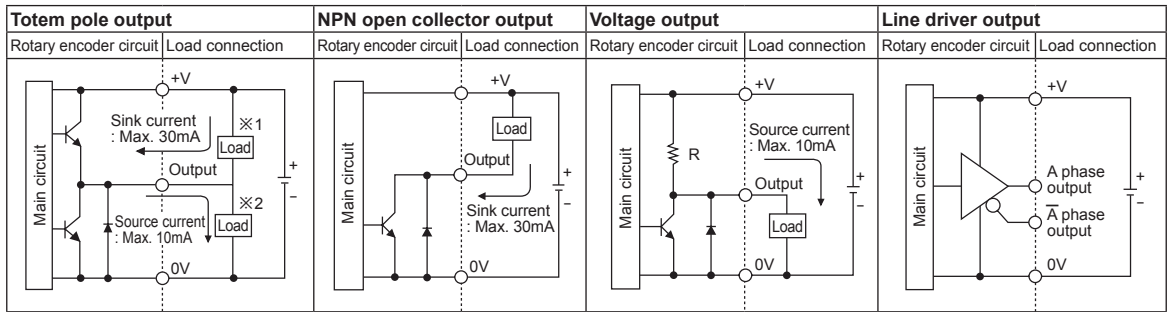

- All output circuits of A, B, Z phase are same. (line driver output is A, \bar{A} , B, \bar{B} , Z, \bar{Z})
- Totem pole output type can be used for NPN open collector type (※1) or voltage output type (※2).

Output Waveforms

- Totem pole output / NPN open collector output / Voltage output

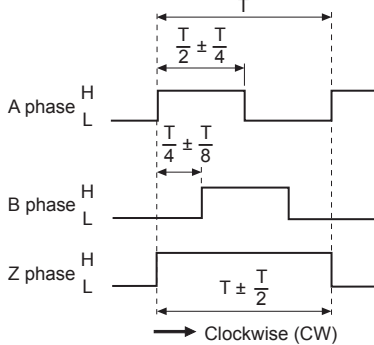

- Line driver output

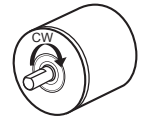
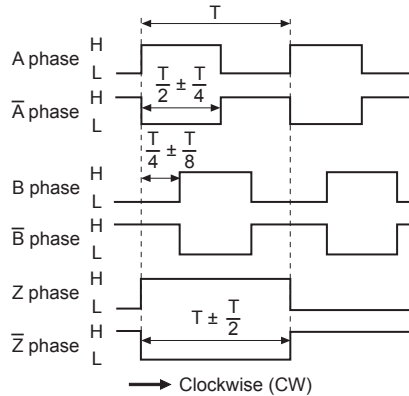

Connections

◎ Axial/Radial Cable type

- Totem pole output / NPN open collector output / Voltage output

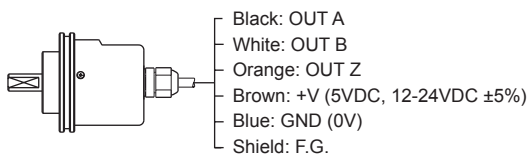

- Line driver output

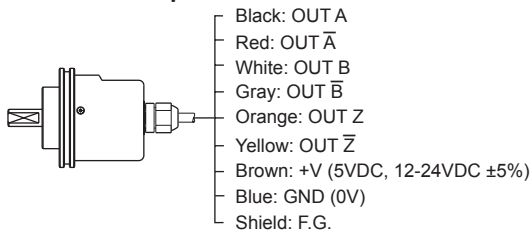

- ※ Unused wires must be insulated.
- ※ The metal cable and shield cable of encoder should be grounded (F.G.)

◎ Axial/Radial cable connector type / Axial/Radial connector type

- Totem pole output / NPN open collector output / Voltage output
- Line driver output

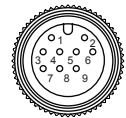

• Totem pole output • NPN open collector output • Voltage output			• Line driver output		
Pin No.	Function	Cable color	Pin No.	Function	Cable color
1	OUT A	Black	1	OUT A	Black
2	OUT B	White	2	OUT \bar{A}	Red
3	OUT Z	Orange	3	+V	Brown
4	+V	Brown	4	GND	Blue
5	GND	Blue	5	OUT B	White
6	F.G.	Shield	6	OUT \bar{B}	Gray
			7	OUT Z	Orange
			8	OUT \bar{Z}	Yellow
			9	F.G.	Shield

※F.G. (field ground): It should be grounded separately.

(A) Photoelectric Sensors

(B) Fiber Optic Sensors

(C) Door/Area Sensors

(D) Proximity Sensors

(E) Pressure Sensors

(F) Rotary Encoders

(G) Connectors/ Connector Cables/ Sensor Distribution Boxes/ Sockets

(H) Temperature Controllers

(I) SSRs / Power Controllers

(J) Counters

(K) Timers

(L) Panel Meters

(M) Tacho / Speed / Pulse Meters

(N) Display Units

(O) Sensor Controllers

(P) Switching Mode Power Supplies

(Q) Stepper Motors & Drivers & Controllers

(R) Graphic/ Logic Panels

(S) Field Network Devices

(T) Software

E58 Series

■ Dimensions

◎ Shaft clamping type

(unit: mm)

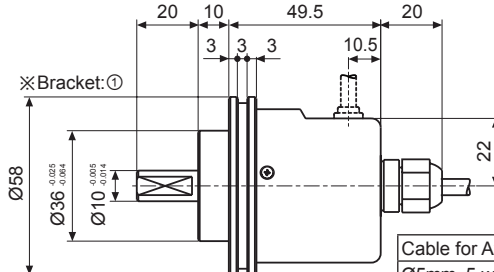
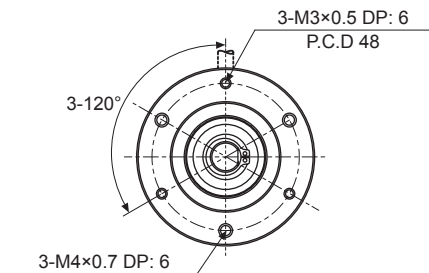
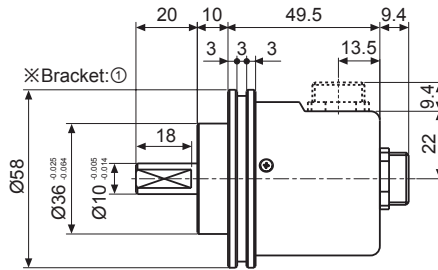
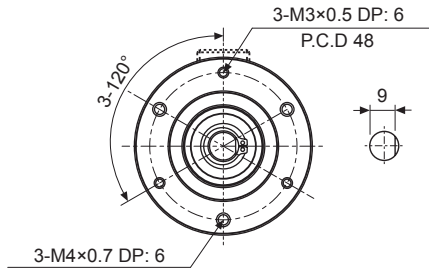

Cable for Axial/Radial cable type
 Ø5mm, 5-wire (line driver output: 8-wire),
 2000mm, Shield cable

◎ Shaft synchro type

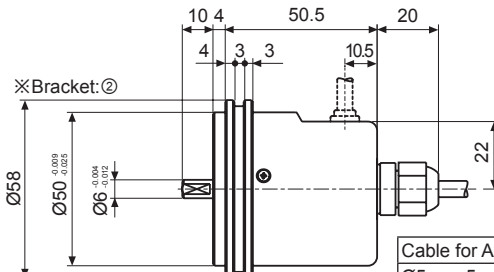
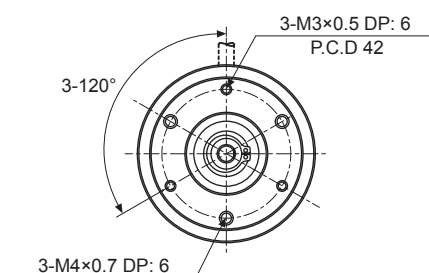
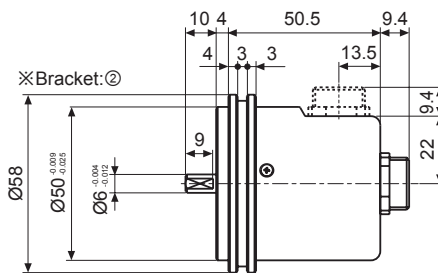
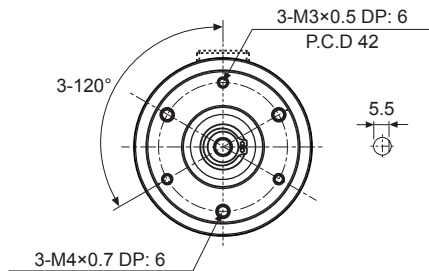

Cable for Axial/Radial cable type
 Ø5mm, 5-wire (line driver output: 8-wire),
 2000mm, Shield cable

● Shaft clamping type, Shaft synchro type Axial/Radial cable connector type

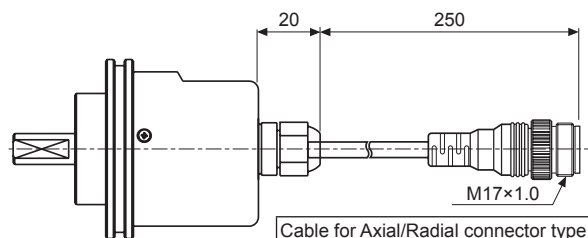
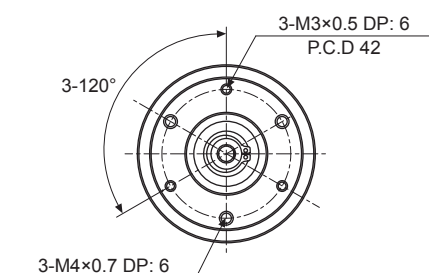

Cable for Axial/Radial connector type
 Ø5mm, 5-wire (line driver output: 8-wire),
 250mm, Shield cable

※Connector cable is sold separately and refer to page G-10 for specifications.

Incremental Ø58mm Shaft/Hollow Shaft/Built-In Type

■ Dimensions

◎ Hollow type

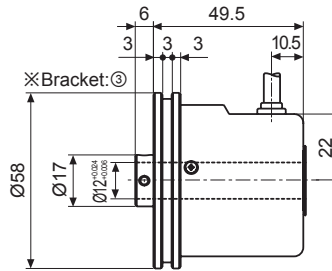
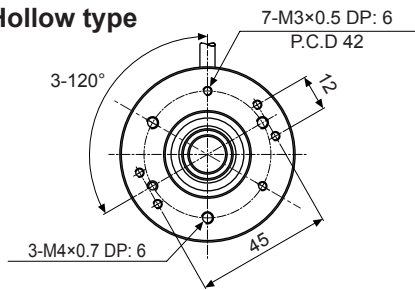

(unit: mm)

Cable for Radial cable type
Ø5mm, 5-wire (line driver output: 8-wire),
2000mm, Shield cable

● Hollow type Radial cable connector type

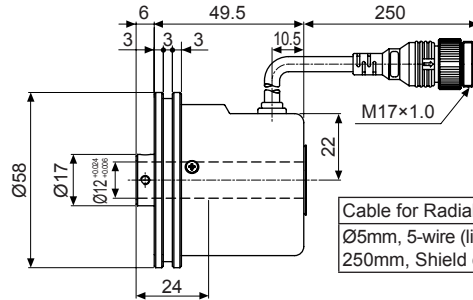
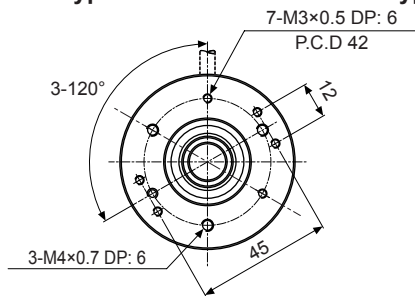

Cable for Radial connector type
Ø5mm, 5-wire (line driver output: 8-wire),
250mm, Shield cable

◎ Hollow built-in type

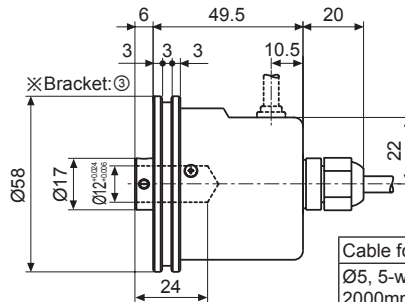
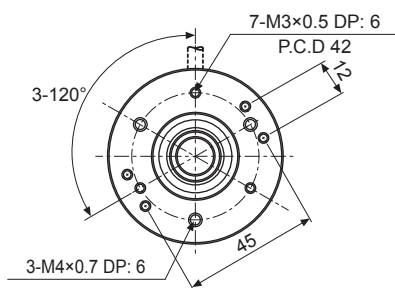
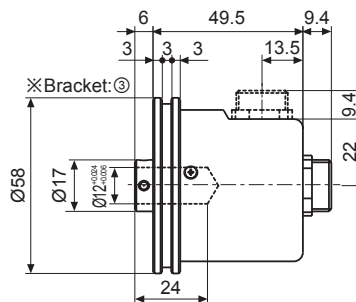
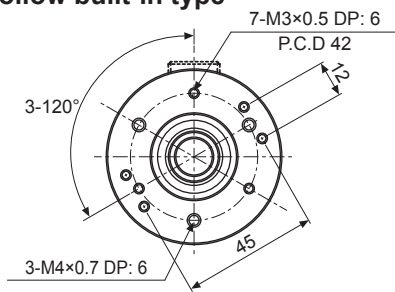

Cable for Axial/Radial cable type
Ø5, 5-wire (line driver output: 8-wire),
2000mm, Shield cable

● Hollow Built-in type Axial/Radial Cable connector type

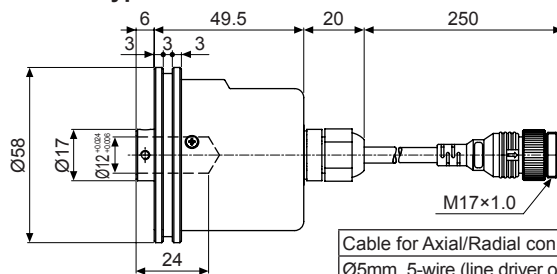
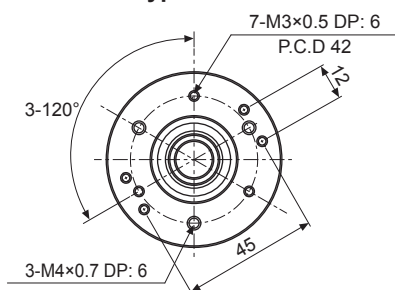

Cable for Axial/Radial connector type
Ø5mm, 5-wire (line driver output: 8-wire),
250mm, Shield cable

※Connector cable is sold separately and refer to page G-10 for specifications.

(A)	Photoelectric Sensors
(B)	Fiber Optic Sensors
(C)	Door/Area Sensors
(D)	Proximity Sensors
(E)	Pressure Sensors
(F)	Rotary Encoders
(G)	Connectors/ Connector Cables/ Sensor Distribution Boxes/ Sockets
(H)	Temperature Controllers
(I)	SSRs / Power Controllers
(J)	Counters
(K)	Timers
(L)	Panel Meters
(M)	Tacho / Speed / Pulse Meters
(N)	Display Units
(O)	Sensor Controllers
(P)	Switching Mode Power Supplies
(Q)	Stepper Motors & Drivers & Controllers
(R)	Graphic/ Logic Panels
(S)	Field Network Devices
(T)	Software

E58 Series

• Bracket

※SC type: ①

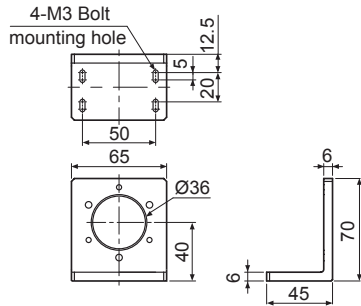

※SS type: ②

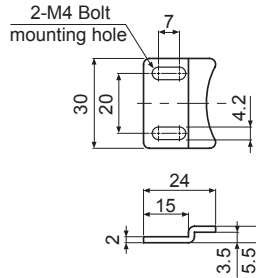

※H/HB type: ③

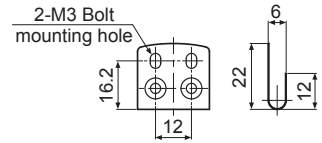

• Ø10mm Coupling (E58SC10 Series)

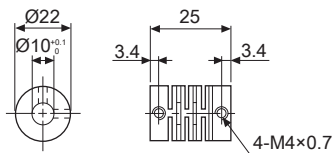

• Ø6mm Coupling (E58SS6 Series)

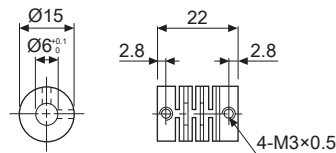

- Parallel misalignment: Max. 0.25mm
- Angular misalignment: Max. 5°
- End-play: Max. 0.5mm

※When mounting the coupling to the encoder shaft, if there is combined misalignment (parallel, angular misalignment) between rotating encoder shaft and mate shaft, it may cause encoder and coupling's life cycle to shorten.

※Do not load overweight on the shaft.

※ For parallel misalignment, angular misalignment, end-play terms, refer to page F-71.

※ For flexible coupling (ERB series) information, refer to page F-64.

کانون ابزار

تلفن :

021 66 39 39 00

0912 147 3023

ali5.ir