

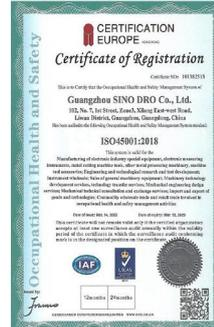

# PRODUCT LIST

## GUANGZHOU SINO DRO Co.,Ltd

-Since 1989



01

## The SDS3 DRO

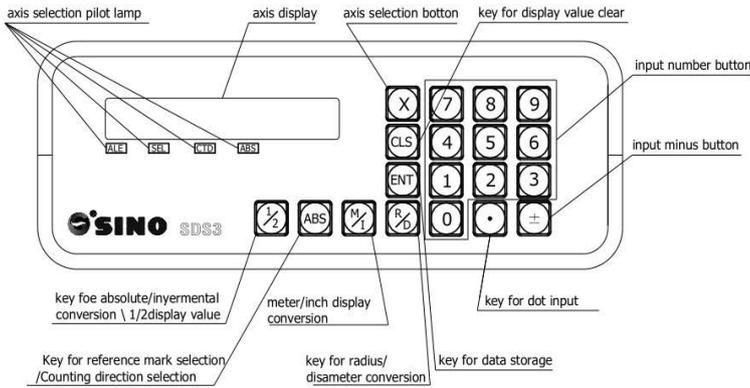

Function / Model	SDS3
Number of Axes	1
Resolution- $\mu\text{m}$	0.1/0.2/0.5 /1/2/5/10
Angle Display	√
Clear to Zero	√
Transfer mm to inch	√
Absolute/Incremental	√
Midsplit	√
Reference Point Tracking	√
Linear Error Compensation	√
Power Interruption Memory	√
Radius / Diameter Conversion	√
Digital Filter	√
Matching Output	√
RS-232-C Interface	√
Height Detecting	√
Progressive Height Detecting	√

### Model No.

SDS3-1 : Standard

SDS3-1F: Extra communication function

SDS3-1E: Extra out put EDM function

SDS3-1C: Extra Height detecting function

### Feature:

Small in size, easy to install,friendly match with different types of machine.The keys are closed micro-motion metal membrane switches, the shape of the keys on the panel is designed to be square.Operation height in accord with human engineering,more pronounced operating feel, more efficiently and comfortably.

02

## The SDS2-3VA DRO

Multifunctional 3 axis digital readout , applicable for machines such as millers, lathes, boring machines, grinding machines, etc

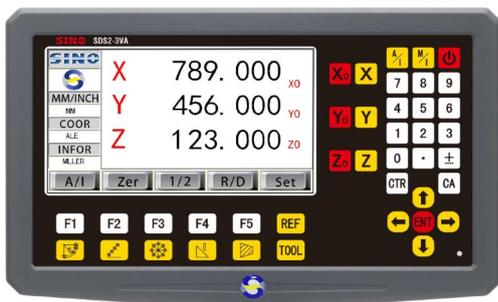

Function / Model	SDS2-3VA
Number of Axes	2/3
Resolution- $\mu\text{m}$	0.05/0.1/0.2/0.5/1/2/5/10
Language -Chinese / English /	√
Brightness Adjustment	√
Angle Display	√
Default Setting	√
Clear to Zero	√
mm/Inch	√
Absolute/Incremental	√
Midsplit	√
Reference Point Tracking	√
200 User Coordinates	√
Mathematics Calculation	√
Linear Error Compensation	√
Non-linear Error Compensation	√
Power Interruption Memory	√
Radius / Diameter Conversion	√
Simple "R"	√

05

## The SDS2MS DRO

Used for multi-functional 2 axis milling machine

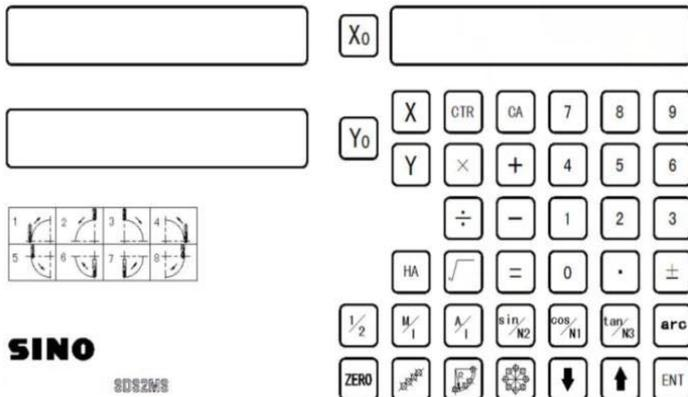

Function / Model	SDS2MS/ 2-3MS
Number of Axes	2/3
Resolution- $\mu\text{m}$	0.1/0.2/0.5 /1/2/5/10
Brightness Adjustment	√
Angle Display	√
Default Setting	√
Clear to Zero	√
mm/Inch	√
Absolute/Incremental	√
Midsplit	√
Reference Point Tracking	√
200 User Coordinates	√
Mathematics Calculation	√
Linear Error Compensation	√
Non-linear Error Compensation	√
Power Interruption Memory	√
Radius / Diameter Conversion	√
Simple "R"	√
Smooth "R"	√
Oblique Line Hole Positioning	√
PCD Circle Equally Dividing	√
Rectangular Inner Chamber Pro	√
Tool Diameter Compensation	√
Bevel Processing	√

06

## The SDS2-3MS DRO

Used for multi-functional 2 axis milling machine



-  Square root calculating key(in Calculation function key)
-  Function key for getting one half
-  Function key for 200 zeroPosition

### Feature:

- \* Robust hardware design coupled with professional software
- \* Achieve more advanced EMC testing targets with significantly improved anti-interference capabilities
- \* Meet the needs of different processing environments

-  Calculation key(in calculationfunction key)
-  Input (calculation result) canceling key(Calculation function key )
-  Key for "Inverting" Trigonometric Functions (in Calculation function key)
-  Key for the conversion the meter System/ British system display
-  Function key for Sleep
-  R angularARC function key(ARC Function key)
-  Function key for circle equally Dividing (PCD Function key)
-  Function key for drilling holes along an oblique

03

## The SDS6-2V DRO

Used for 2 axis milling machine, grinding machine and lathe machine



**Model No.**

SDS6-2V : Standard

SDS6-2VF : Extra communication function

**Advantage:**

- Imported chips
- Industrial quality
- High precision data
- Stronger resistance to interference
- Function key for data filtration

04

## The SDS6-3V DRO

Used for 3 axis milling machine, lathe machine and discharging processing



**Model No.**

SDS6-3V : Standard

SDS6-3VF : Extra communication function

SDS6-3VE : Extra out put EDM function

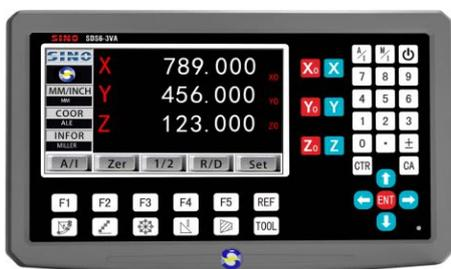

NEW ARRIVAL  
SDS6-3VA

Function / Model	SDS6
Number of Axes	2/3
Resolution- $\mu\text{m}$	0.1/0.2/0.5 /1/2/5/10
Brightness Adjustment	√
Angle Display	√
Default Setting	√
Clear to Zero	√
mm/Inch	√
Absolute/Incremental	√
Midsplit	√
Reference Point Tracking	√
200 User Coordinates	√
Mathematics Calculation	√
Linear Error Compensation	√
Non-linear Error Compensation	√
Power Interruption Memory	√
Radius / Diameter Conversion	√
Simple "R"	√
Smooth "R"	√
Oblique Line Hole Positioning	√
PCD Circle Equally Dividing	√
Rectangular Inner Chamber Progressive Machining	√
Tool Diameter Compensation	√
Bevel Processing	√
Digital Filter	√
Matching Output	√
RS-232-C Interface	√
Taper Measurement	√
200 Tools Storeroom	√

**Feature:**

- Imported chips
- Industrial quality
- High precision data
- Stronger resistance to interference
- Function key for machine output(EDM)

07

## The SDS5-4VA DRO

Multifunction universal 5-coordinate 5 axis display digital readout, applicable for the machines such as millers, lathes, boring machines, grinding machines and EDM, etc

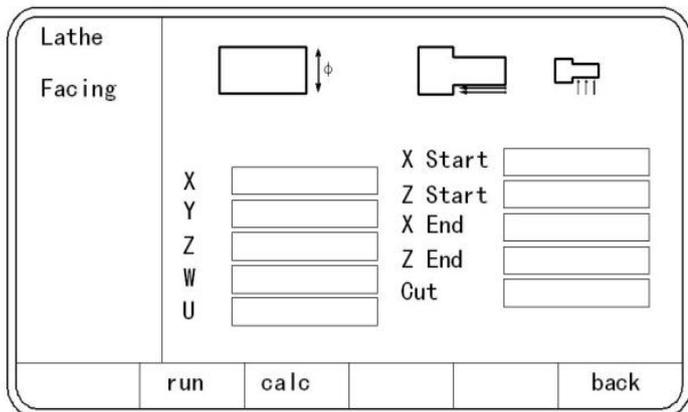
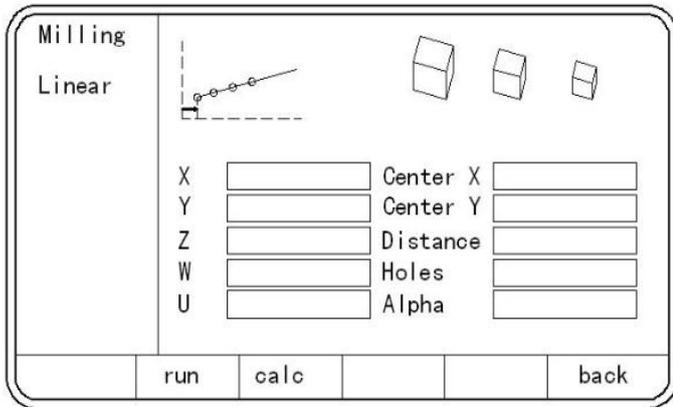

Function / Model	SDS5-4VA
Number of Axes	1/2/3/4/5
Resolution- $\mu$ m	0.1/0.2/0.5/1/2/5/10
Brightness Adjustment	√
Color Exchange	√
Angle Display	√
Default Setting	√
Clear to Zero	√
mm/Inch	√
Absolute/Incremental	√
Midsplit	√
Reference Point Tracking	√
200 User Coordinates	√
Mathematics Calculation	√
Linear Error Compensation	√
Non-linear Error Compensation	√
Power Interruption Memory	√
Radius / Diameter Conversion	√
Simple "R"	√
Smooth "R"	√
Oblique Line Hole Positioning	√
PCD Circle Equally Dividing	√
Rectangular Inner Chamber Pro	√
Tool Diameter Compensation	√
Bevel Processing	√
Digital Filter	√
aper Measurement	√
200 Tools Storeroom	√
Grid Drilling	√
Cylindrical/End Surface Proces	√

**Feature:**

Five-axis input, four-axis display; High-speed data transfer between USB devices and PCs with RS 485 and RS-232 communication capabilities. The facilitation of system upgrades; The key uses a fretted metal shrapnel switch

## The SDS200 DRO

Multifunction universal 5-coordinate 4 axis display digital readout, applicable for the machines such as millers, lathes, boring machines, grinding machines and EDM, etc

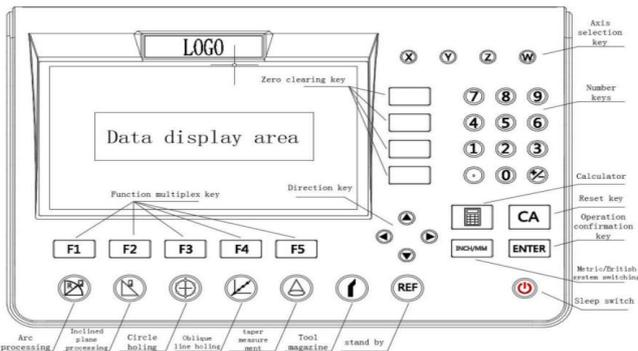

SDS200 (4 axes) standard

SDS200-L(3 axes) with Gear Ratio function

Function / Model	SDS 200 SDS200S
Number of Axes	2/3/4
Resolution- $\mu\text{m}$	0.05/0.1/0.2/0.5/1/2/5/10
Language -Chinese / English / Deutsch / French / Espanol	✓
Brightness Adjustment	✓
Angle Display	✓
Default Setting	✓
Clear to Zero	✓
mm/Inch	✓
Absolute/Incremental	✓
Midsplit	✓
Reference Point Tracking	✓
200 User Coordinates	✓
Mathematics Calculation	✓
Linear Error Compensation	✓
Non-linear Error Compensation	✓
Power Interruption Memory	✓
Radius / Diameter Conversion	✓
Simple "R"	✓
Oblique Line Hole Positioning	✓
PCD Circle Equally Dividing	✓
Bevel Processing	✓
Digital Filter	✓
Taper Measurement	✓
200 Tools Storeroom	✓

## The SDS200S MINI DRO

Supper mini dro, touch screen

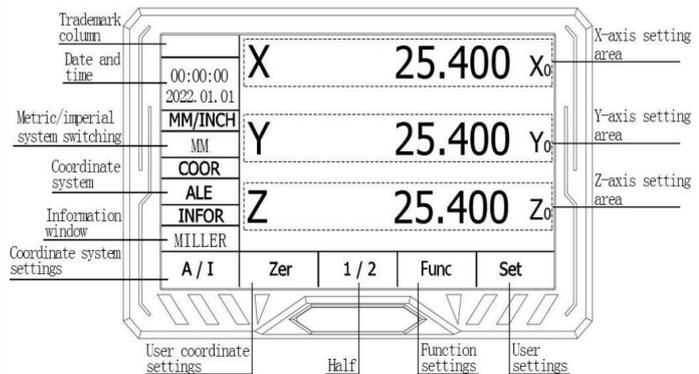

Main purpose of providing detecting and locating functions for test instruction or during the processing of various manual machine tools of different types

# KA Series Closed Linear Grating Scale

All KA series of linear encoder have passed the strict quality examination by the advanced dynamic laser interferometer to ensure the high precision. Test reports for each scale are available. KA-300 and KA-600 are the most commonly used standard ruler; KA-200, KA500 are a super-miniature ruler, it facilitates the use in some narrow places and the installation of special purpose measuring instrument.

01

## KA-600 Series (from 100mm up to 3000mm)



Model No	KA-600
Resolution	0.5μm, 1 μm, 5 μm

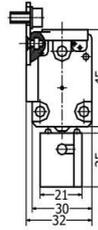
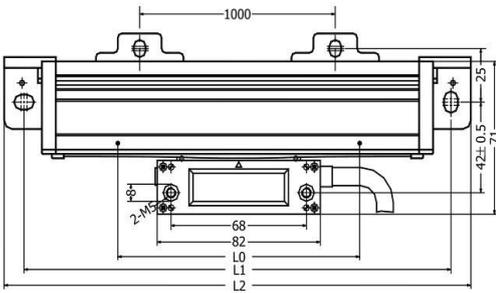

Model	L0	L1	L2	Model	L0	L1	L2
KA600-1000	1000	1150	1170	KA600-2100	2100	2250	2270
KA600-1100	1100	1250	1270	KA600-2200	2200	2350	2370
KA600-1200	1200	1350	1370	KA600-2300	2300	2450	2470
KA600-1300	1300	1450	1470	KA600-2400	2400	2550	2570
KA600-1400	1400	1550	1570	KA600-2500	2500	2650	2670
KA600-1500	1500	1650	1670	KA600-2600	2600	2750	2770
KA600-1600	1600	1750	1770	KA600-2700	2700	2850	2870
KA600-1700	1700	1850	1870	KA600-2800	2800	2950	2970
KA600-1800	1800	1950	1970	KA600-2900	2900	3050	3070
KA600-1900	1900	2050	2070	KA600-3000	3000	3150	3170
KA600-2000	2000	2150	2170				

L0:Effective measuring length of encoder ; L1:Dimension of encoder mounting hole ; L2:Encoder overall dimension

02

## KA-300 Series (from 70mm up to 1020mm)

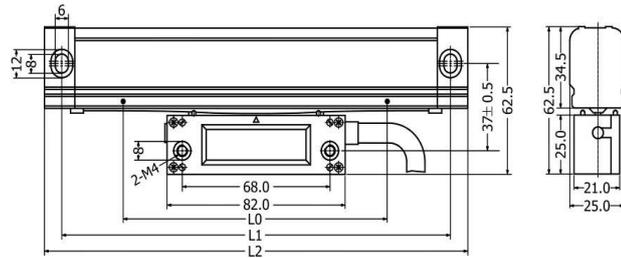

Model No	KA-300
Resolution	0.5μm, 1 μm, 5 μm

Model	L0	L1	L2	Model	L0	L1	L2
KA300-70	70	160	176	KA300-570	570	660	676
KA300-120	120	210	226	KA300-620	620	710	726
KA300-170	170	260	276	KA300-670	670	760	776
KA300-220	220	310	326	KA300-720	720	810	826
KA300-270	270	360	376	KA300-770	770	860	876
KA300-320	320	410	426	KA300-820	820	910	926
KA300-370	370	460	476	KA300-870	870	960	976
KA300-420	420	510	526	KA300-920	920	1010	1026
KA300-470	470	560	576	KA300-970	970	1060	1076
KA300-520	520	610	626	KA300-1020	1020	1110	1126

Regular 5 V, TTL signal, 3 meter cable

Pls contact us:

- \*If RS422 (EIA-422-A) is needed
- \*If other cable length is needed
- \*If 24V (only TTL signal) is needed

L0:Effective measuring length of encoder ; L1:Dimension of encoder mounting hole ; L2:Encoder overall dimension

03

### KA-500 Series (SLIM)

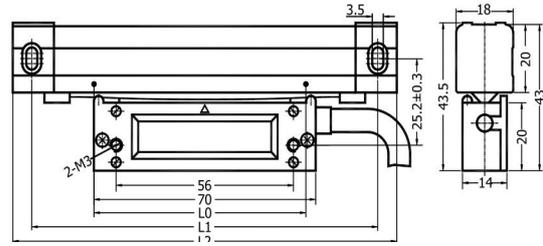

Model No	KA-500
Resolution	1 μm, 5 μm

Model	L0	L1	L2	Model	L0	L1	L2
KA500-70	70	172	182	KA500-420	420	522	532
KA500-120	120	222	232	KA500-470	470	572	582
KA500-170	170	272	282	KA500-520	520	622	632
KA500-220	220	322	332	KA500-570	570	672	682
KA500-270	270	372	382	KA500-620	620	722	732
KA500-320	320	422	432	KA500-670	670	772	782
KA500-370	370	472	482	KA500-720	720	822	832

04

### KA-200 Series (Super mini)

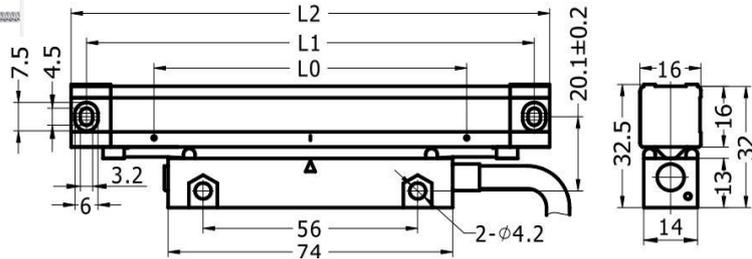

Model No	KA-200
Resolution	1 μm, 5 μm

Model	L0	L1	L2	Model	L0	L1	L2
KA200-30	30	125	133	KA200-160	160	255	263
KA200-40	40	135	143	KA200-170	170	265	273
KA200-50	50	145	153	KA200-180	180	275	283
KA200-60	60	155	163	KA200-190	190	285	293
KA200-70	70	165	173	KA200-200	200	295	303
KA200-80	80	175	183	KA200-220	220	315	323
KA200-90	90	185	193	KA200-240	240	335	343
KA200-100	100	195	203	KA200-260	260	355	363
KA200-110	110	205	213	KA200-280	280	375	383
KA200-120	120	215	223	KA200-300	300	395	403
KA200-130	130	225	233	KA200-320	320	415	423
KA200-140	140	235	243	KA200-340	340	435	443
KA200-150	150	245	253	KA200-360	360	455	463

Regular 5 V, TTL signal, 2 meter cable

Pls contact us  
If RS422 (EIA-422-A) is needed

## KA-800 Series Incremental Magnetic Encoder

KA-800 Series can be connectable for length purpose that longer than 3000mm, the max length can be 50m/100m, the appearance of KA-800 will further broaden the application field of digital readout system.

05

## KA800M Sealed Magnetic Encoder



- \* High precision of up to  $\pm 10\mu\text{m} / 300\text{mm}$  or  $\pm 20\mu\text{m} / 1000\text{mm}$ ,
- \* Resolution:  $1\mu\text{m}, 5\mu\text{m}$
- \* Measurement length of up to 2 m u p t o 100m
- \* Max. moving speed: 30m/min
- \* Pitch optional 1,  $1\mu\text{m}+1\text{mm}$  pitch  
optional 2,  $1\mu\text{m}+2\text{mm}$  pitch  
optional 3,  $5\mu\text{m}+2\text{mm}$  pitch

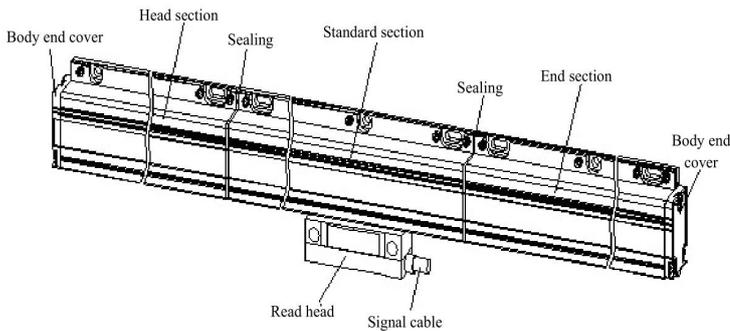

06

## KA800MC Exposed Magnetic Encoder



### 1. Type: 5+5mm pitch

- \* Magnetic scaling distance : 5mm
- \* Resolution:  $5\mu\text{m}$
- \* Accuracy :  $\pm (0.035 + 0.02 \times L)$  mm,  
L:effective measuring length
- \* Long cables can be provided as required,  
and the maximum cable lengths  
are as follows:  
LMAX=50m (Read head cable)  
LMAX=100m (3m reader cable +  
extension cable)

### 2 Type: 2+2mm pitch (NEW)

- \* Magnetic scaling distance : 2mm
- \* Resolution:  $5\mu\text{m} / 1\mu\text{m}$

07

## KA800MC-5 Open-type - MINI Magnetic Encoder



- \* Magnetic scaling distance : 5mm
- \* Resolution:  $5\mu\text{m}$
- \* Measurement length from 70mm up to 520mm

**08** RA-A Angle Encoder

**Electric Parameters of RA-A High-Precision Angle Encoder**

**Number of outgoing lines (L/R) 180000**



TYPE	Accuracy :
RA-AB10N-CR180000	±5~8s
RA-AB10N-CR180000	±3~5s

Operating voltage, 5V±5% , 210mA

Allowable electric rotating speed 120rpm

Output signal frequency: Max 200KHz

**09**  
**OUR PROJECT**



## SINO Protect cover for linear encoder

### \*Protect cover for KA-300

1) Economical cover **C** type



2) Full protect cover **X** type



3) Full protect cover **D** type



### \*Protect cover for KA-600



### \*Protect cover for slim KA-500



### \*Protect cover for mini KA-200

**SINO Accessories List**

\*Support arm of DRO display

1. Arm for Milling/grinding/boring/EDM machine

**L400**  
40cm



**L500**  
50cm



2. Arm for lathe

Regular **Rack for lathe**



**Lexury 50C**



**Lexury 63C**



3. Table support arm



\*Assemble T-bracket for scales

Economical 4 pcs/set  $A2+B3+C2+D2$



Short length less than 670mm  $B3+D2$   
Longer using  $A2+C2$

More than 1000mm, recomend 4pcs/set  
Or Stronger T-bracket  $A+B+C+D$



**Guangzhou SINO DRO Co. Ltd**  
**Guangzhou SINO International Trade Co.,Ltd**

Contact person: Berlina Zhang  
Mob: +86- 18620615002  
WhatsApp/wechat:+86-18620615002  
Skype: berlina2009  
Email: [infos@sino-ld.com](mailto:infos@sino-ld.com)

Website: <http://sino-ld.com>  
Factory Add: No .7,1st Street,Zone 3 Xilang East-west Road, Liwan District, Guangzhou, Guangdong,China

**كانون ابزار**

**تلفن :**

**021 66 39 39 00**

**0912 147 3023**

**ali5.ir**